

Series		Description	Size													Mounting			Page
Parker	Denison		1/8	1/4	3/8	1/2	3/4	1	06	10	16	25	32	Subplate	Screw-in	Slip-in			
		Parker Standard DIN / ISO																	
		<b>Shuttle valves</b>																	
SSR	–								•	•					•		6-3		
		<b>Check valves, direct operated</b>																	
RK / RB	–		•	•	•	•									•		6-5		
CS	–			•	•	•	•							•			6-9		
SPZBE	–										•	•	•			•	6-11		
SPV / SPZ	–								•	•					•		6-13		
SPR	C4V									•		•	•	•			6-15		
		<b>Check valves, pilot operated</b>																	
CPS	–				•									•			6-19		
	D4S	2/2 way seat valves								•		•	•	•			6-21		
SVLE	C4V									•		•	•	•			6-31		
		<b>Accessories</b>																	
		Plugs															6-35		

More check valves are presented in the following chapters:  
**Chapter 7: Sandwich Valves**  
**Chapter 8: Slip-In Cartridge Valves**  
**Chapter 9: SAE Flange Valves**  
**Chapter 10: Valves for Pipe Mounting**



The shuttle valve series SSR is designed as a threaded cartridge valve. All parts are assembled in one unit and easy to mount.

**Features**

- Little space required
- Leak-free
- Easy assembly

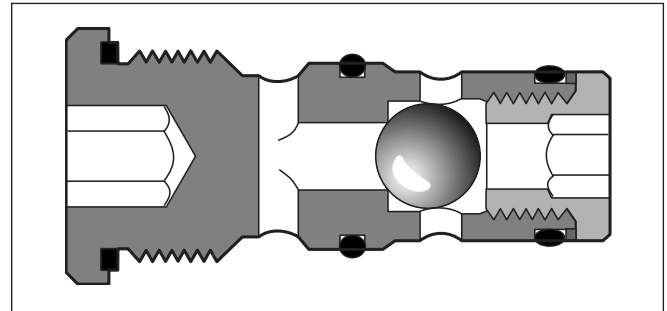

**Technical data**

<b>Design</b>	Threaded cartridge valve	
Mounting position	Unrestricted	
Ambient temperature	-40 ... +60 [°C]	
Nominal size	NG06	NG10
Weight	0.5 [kg]	0.8
<b>Hydraulic</b>	See symbols	
Flow direction	Hydraulic oil as per DIN 51 524 ... 525	
Fluid		
Viscosity	recommended [cSt] [mm²/s]	30 ... 80
	permitted [cSt] [mm²/s]	20 ... 380
Fluid temperature	-20 ... +60 [°C]	
Filtration	ISO 4406 (1999); 18/16/13	
Nominal pressure	350 [bar]	
Flow	40 [l/min]	60

**6**

**Ordering code**

	<b>SSR</b>	<b>B</b>	<b>080</b>	<b>E</b>	
Seal	Shuttle valve	Design series	Factory norm, direct operated	Threaded cartridge	Valve size

Code	Seal		Code	Size
omit	<b>NBR</b>		<b>06</b>	<b>NG06</b>
V	FPM		<b>10</b>	<b>NG10</b>

**Bold letters =  
Short-term availability**

**Dimensions**

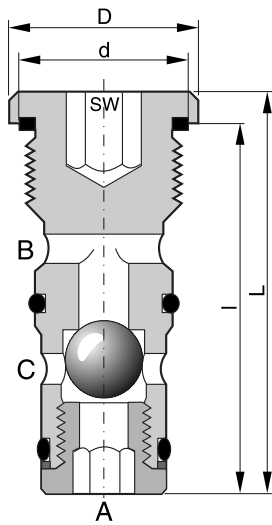

Dimensions	NG06	NG10
D	24	34
L	50	74
d	M18x1.5	M24x1.5
I	45	66
SW	8	12

**Seal kits**

6

NG	NBR seals	FPM seals
06	SK-SSRB0E06	SK-SSRB0E06V
10	SK-SSRB0E10	SK-SSRB0E10V

**Mounting cavity**

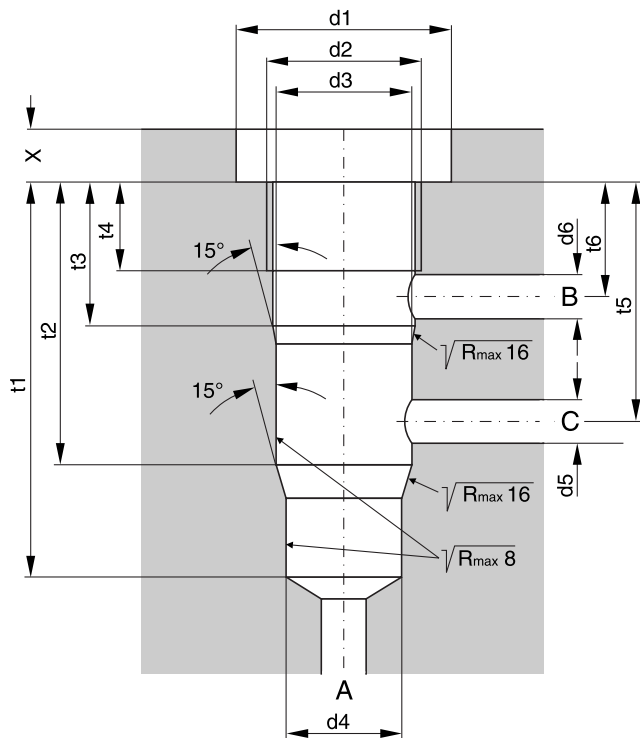

Dimensions	NG06	NG10
d1	25	35
d2	M18 x 1.5	M24 x 1.5
d3 <sup>H7</sup>	16	22
d4 <sup>H7</sup>	14	20
d5 <sub>max.</sub>	6	9
d6 <sub>max.</sub>	6	9
t1	45	68
t2	32	51
t3	16	20
t4	10	15
t5	27.5	40
t6	12	13.5

The check valves are designed to go into simple, threaded cavities. The connection is O-ring sealed on the 118° shoulder in the mounting cavity.

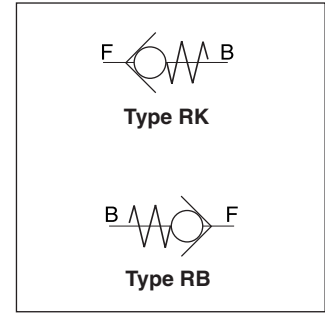

**Technical data**

Series design with pipe thread

Code		RK0	RK1	RK2	RK3	RB1	RB2	RB3
Flow	[l/min]	10	20	50	80	20	50	80
Operating pressure	[bar]	700	700	700	500	700	700	500
Opening pressure	[bar]	0.15	0.18	0.2	0.25	0.15	0.07	0.17
Thread (DIN ISO 228/1)		G1/8A	G1/4A	G3/8A	G1/2A	G1/4A	G3/8A	G1/2A
Tightening torque* ±20%	[Nm]	10	15	20	40	15	20	40
Weight	[g]	5	5	15	15	5	15	20
Mounting position		unrestricted						
Fluid		Hydraulic oil in accordance with DIN 51524/51525						
Viscosity permitted	[cSt]/[mm²/s]	4...1500 ; opt. 10...500 viscosity recommended						
Temperatures	[°C]	Ambient and oil -40...+80, observe viscosity range.						

\* In case of strong vibration, it is recommended to secure the mounting threads.

**6**

**Ordering code**

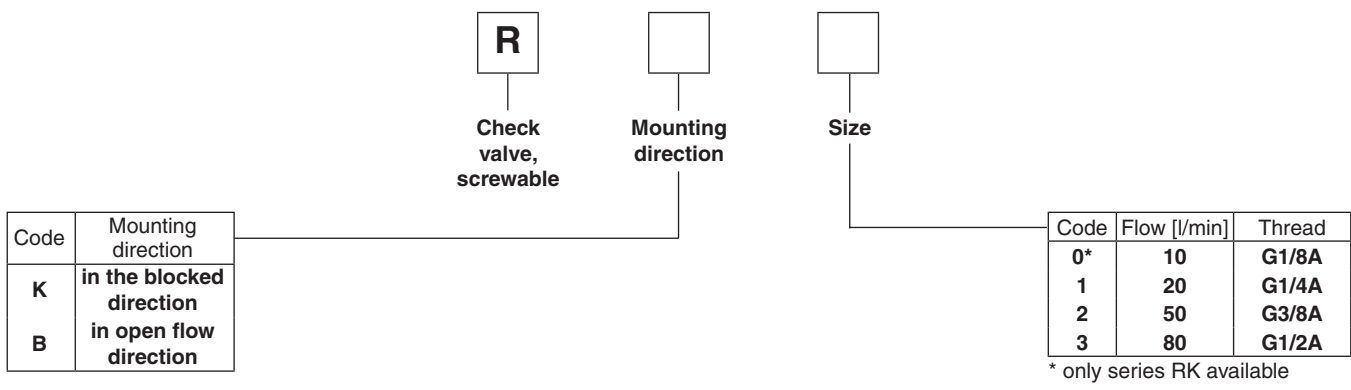

**Bold letters =  
Short-term availability**

**Characteristics**

**$\Delta p/Q$  performance curves**

Oil viscosity during measurement 50mm<sup>2</sup>/s

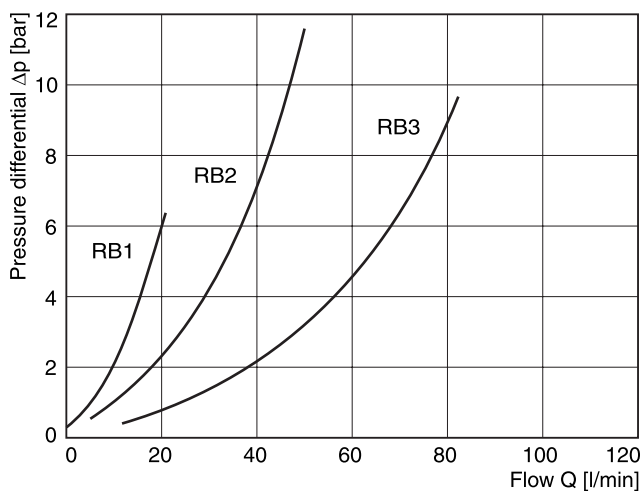
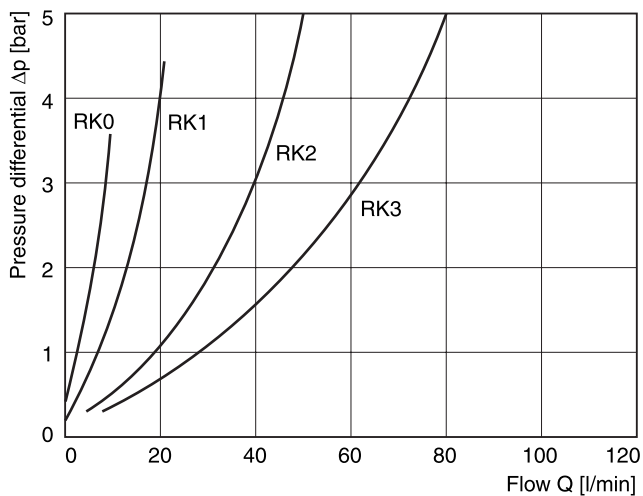

**6**

**Mounting direction**

**Type RK**

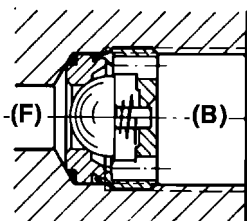

Screwed in,  
in the blocked direction

**Type RB**

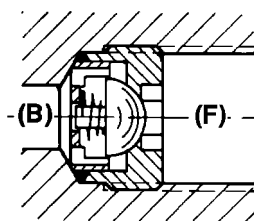

Screwed in,  
in the open flow direction

**Mounting tool**

**Type RK**

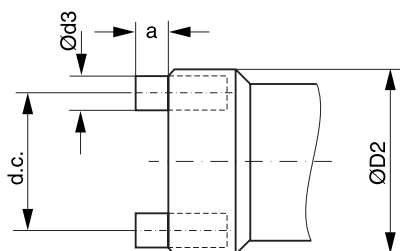

Type	D <sub>2</sub>	a	d <sub>3</sub>
RK0	8.6	2	1.5
RK1	11.5	2.5	2
RK2	15	2	2.5
RK3	18.8	4	3.5

**Type RK**

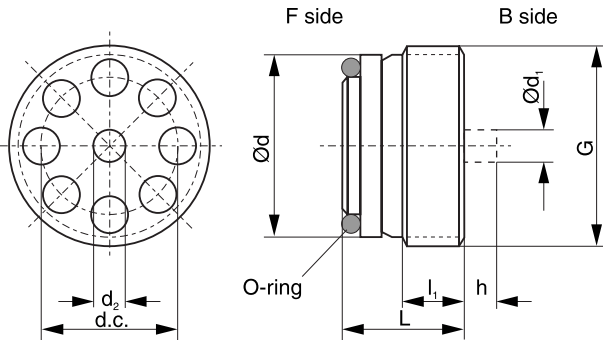

**Type RB**

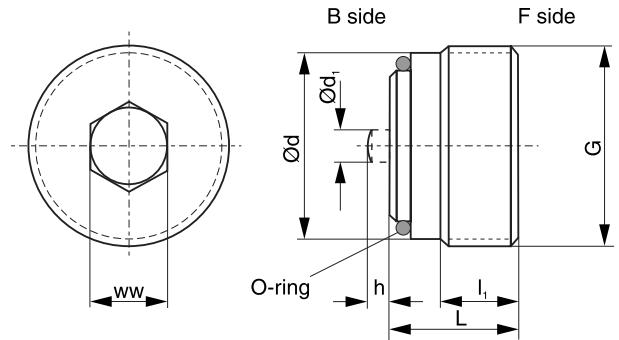

Type	Thread	L	l <sub>1</sub>	d	d <sub>1</sub>	d <sub>2</sub>	h	d.c.	O-ring
RK0	G1/8A	7.2	4	8.6	1.8	1.6	1.3	6.8	6x1
RK1	G1/4A	9	4.5	11.5	2.4	2.2	1.5	8.8 <sub>-0.1</sub>	9x1
RK2	G3/8A	11	6	15	3.2	3	2.5	11	11x1.5
RK3	G1/2A	13	7.5	18.5	4	3.8	3	14.2 <sub>-0.1</sub>	14x1.5

Type	Thread	L	l <sub>1</sub>	d	d <sub>1</sub>	h	ww	O-ring
RB1	G1/4A	9.8	5	11.6	2	1.3	5	9x1
RB2	G3/8A	11.5	7.0	15	2.8	2	6	11x1.5
RB3	G1/2A	13.15	7.5	18.5	3.2	2.5	8	14x1.5

**Mounting cavity**

- for connecting in combination with tube fitting

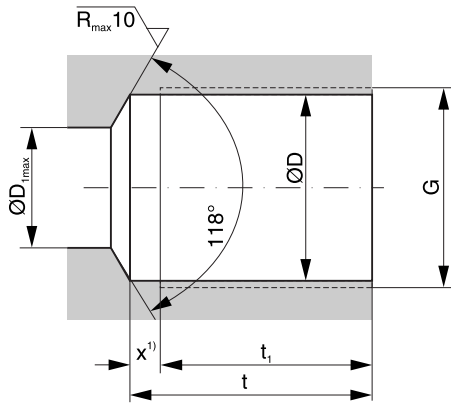

- for internal line channels

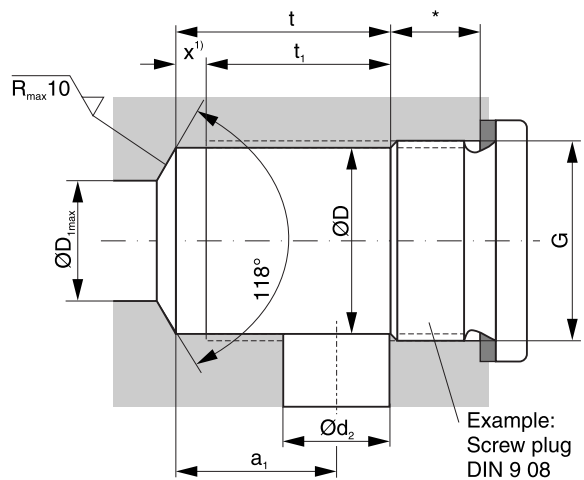

\* Required depth depending on type of screw plug, connecting plate, etc. used.

Type	Thread	D	D <sub>1</sub>	t	t <sub>1</sub> <sup>2)</sup>	x <sup>1)</sup>
RK0	G1/8	8.7	5	16	13.7	2.3
RK1 and RB1	G1/4	11.8	8	22	19	3
RK2 and RB2	G3/8	15.25	9	24.5	21.5	3
RK3 and RB3	G1/2	19	12	29	25.5	3.5

Type	Thread	D	D <sub>1</sub>	t	t <sub>1</sub> <sup>2)</sup>	x <sup>1)</sup>	a <sub>1</sub>	d <sub>2</sub>
RK0	G1/8	8.7	5	12.3	10	2.3	9.5	5
RK1 and RB1	G1/4	11.8	8	14	11	3	11	6
RK2 and RB2	G3/8	15.25	9	17	14	3	13	8
RK3 and RB3	G1/2	19	12	22	18.5	3.5	16	12

<sup>1)</sup> Thread runout x must be maintained. It may be smaller, but not larger (requirement for a perfect seal using the O-ring).

<sup>2)</sup> Fully cut-out thread



**Characteristics / Ordering Code**

Manatrol check valves of the series CS for subplate mounting provide free flow in one direction and block flow in the counter direction. Depending on the material specifications, these valves are suited for use in hydraulic and pneumatic systems.

Specific Manatrol poppets and poppet guides ensure reliable functional integrity even at high flow rates and/or pulsations.

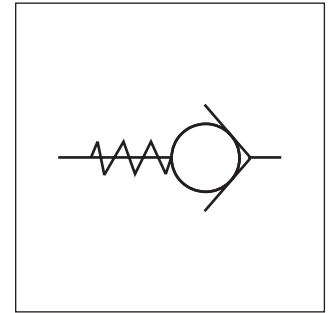
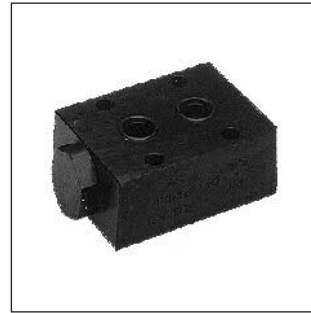

**Technical data**

Size		400	600	800	1200	1600
Operating pressure	[bar]	350	350	350	350	210
Pressure drop $\Delta p$	[bar]	10	10	10	1	1
Flow	[l/min]	65	110	155	112	160

**$\Delta p/Q$  performance curves**

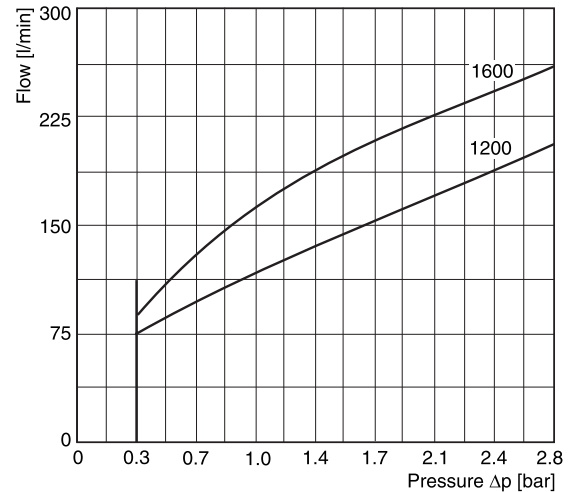
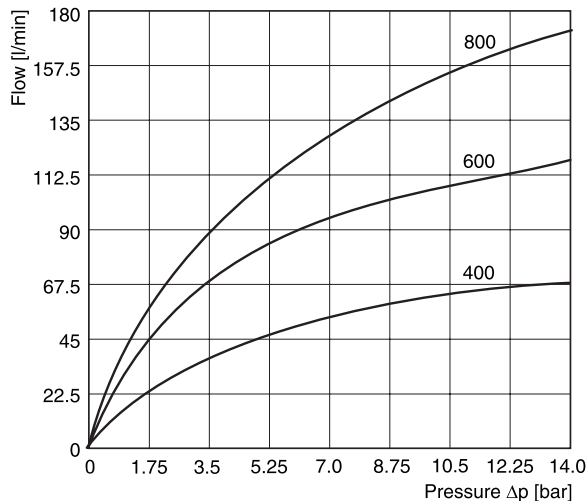

The curves refer to hydraulic oil of 33 cSt and 50°C.

**Ordering code**

<b>CS</b>		<b>S</b>		
Manifold design	Nominal size	Steel body	Opening pressure	Seal

Code	Size
400	400 (1/4)
600	600 (3/8)
800	800 (1/2)
1200	1200 (3/4)
1600	1600 (1)

Code	Seal
omit	<b>NBR</b>
V	FPM

Code	Pressure [bar]
omit	<b>0.35</b>
65	4.5

**Bold letters = Short-term availability**

Dimensions

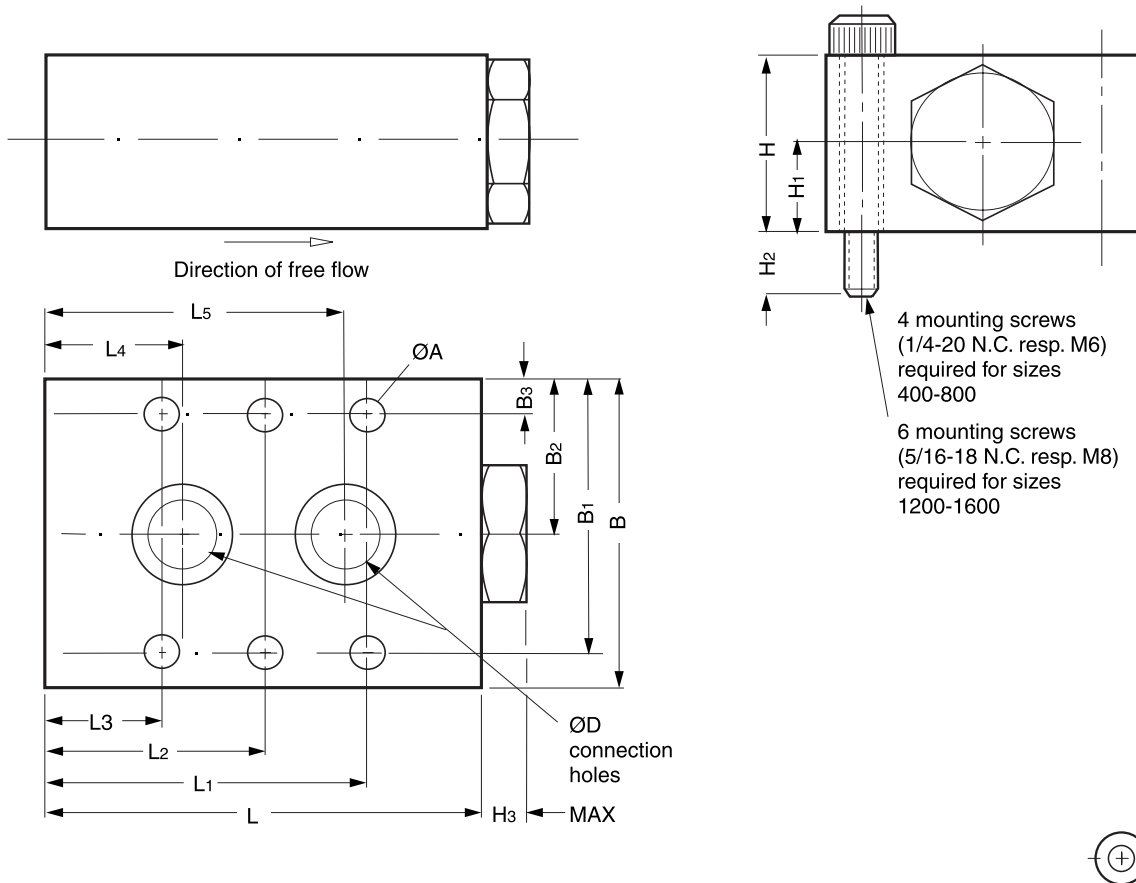

6

Size	ØD	ØA	L	L1	L2	L3	L4	L5	B3	B2	B1	B	H	H1	H2	H3	Weight [kg]
CS 400S	7.1	6.35	63.5	49.0	-	14.2	19.1	44.5	5.3	22.1	38.9	44.5	22.1	10.9	9.9	7.9	0.5
CS 600S	10.2	6.35	69.9	51.6	-	18.0	22.1	47.5	6.4	25.4	44.5	50.8	25.4	12.7	13.0	8.1	0.7
CS 800S	11.9	6.35	80.7	59.4	-	21.3	25.4	55.6	6.4	28.4	50.8	57.2	31.8	15.7	13.2	8.1	1.0
CS 1200S	17.3	8.5	103.9	89.9	51.8	13.7	25.1	79.2	7.9	34.8	61.7	69.9	44.5	22.1	14.5	10.7	2.3
CS 1600S	22.1	8.5	127.0	111.0	63.5	15.7	34.8	91.9	7.9	38.1	68.1	76.2	50.8	25.4	14.5	10.7	3.5

The check valves series SPZBE are slip-in cartridge valves. The function unit is fixed inside the manifold by a plug with hex slot.

The design is based on CE series with same poppet and sleeve. The different mounting cavity has to be considered.

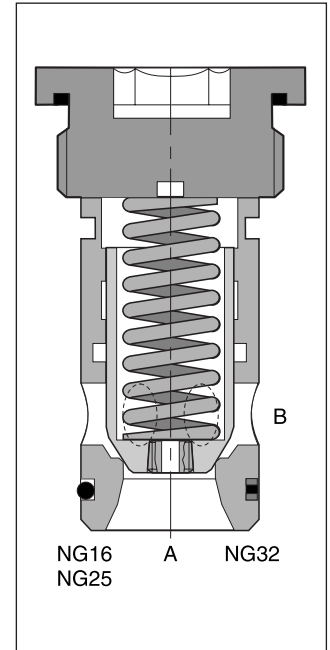
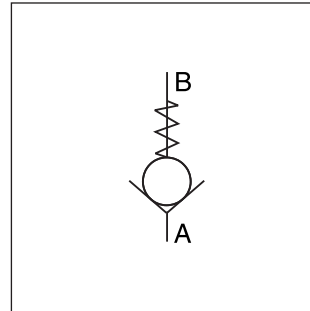

**Features**

- Little space required
- Leak-free from port B to A
- 4 different opening pressures

**Technical data**

<b>Design</b>		Threaded cartridge valve		
Mounting position		Optional		
Ambient temperature	[°C]	-40 ... +60		
Nominal size		NG16	NG25	NG32
Weight	[kg]	0.25	0.5	1.2
<b>Hydraulic</b>		Port A to B		
Flow direction		Hydraulic oil as per DIN 51 524 ... 536		
Fluid				
Viscosity	recommended [cSt] [mm²/s]	30 ... 80		
	permitted [cSt] [mm²/s]	20 ... 380		
Fluid temperature	[°C]	-20 ... +60		
Filtration		ISO 4406 (1999); 18/16/13		
Nominal pressure	[bar]	350		
Opening pressure	[bar]	0.1; 0.5; 1.6 and 4.0		
Flow	[l/min]	250	450	900

**Ordering code**

	<b>SP</b>	<b>Z</b>	<b>B</b>	<b>1010</b>	<b>E</b>		
Seal	Check valve	Flow direction A to B	Design series, screwed cover	Factory norm, poppet, direct operated	Slip-in valve	Valve size	Opening pressure

Code	Seal
omit	<b>NBR</b>
V	FPM

Code	Pressure [bar]
L	0.1
<b>N</b>	<b>0.5</b>
S	1.6
U	4.0

Code	Size
<b>16</b>	<b>NG16</b>
<b>25</b>	<b>NG25</b>
<b>32</b>	<b>NG32</b>

**Bold letters =  
Short-term availability**

**Performance curves**

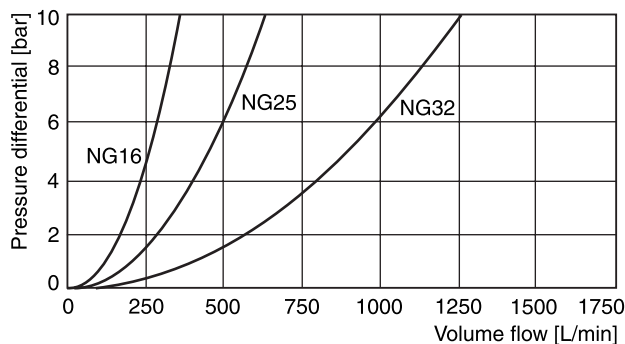

**Dimensions**

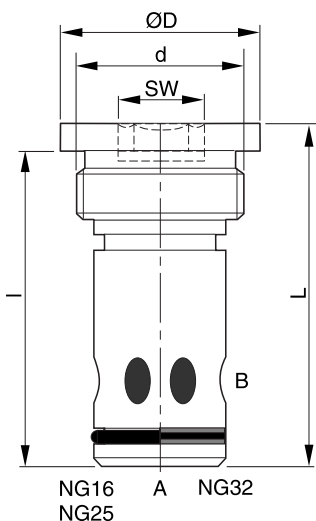

Dimensions	NG16	NG25	NG32
D	40	55	72
L	72.5	89	109.5
d	M33x2	G1½"	G2"
l	66	80.5	99.5
SW	17	24	32

6

**Seal kits**

NG	NBR seals	FPM seals
16	SK-SPZBE10E16	SK-SPZBE10E16V
25	SK-SPZBE10E25	SK-SPZBE10E25V
32	SK-SPZBE10E32	SK-SPZBE10E32V

**Springs**

Spring Type	Ordering Number		
	NG16	NG25	NG32
L 0.1 bar	45051368	45051375	45051376
N 0.5 bar	45051369	45051374	45051377
S 1.6 bar	45051370	45051372	45051378
U 4.0 bar	45051371	45051373	45051379

**Mounting cavity**

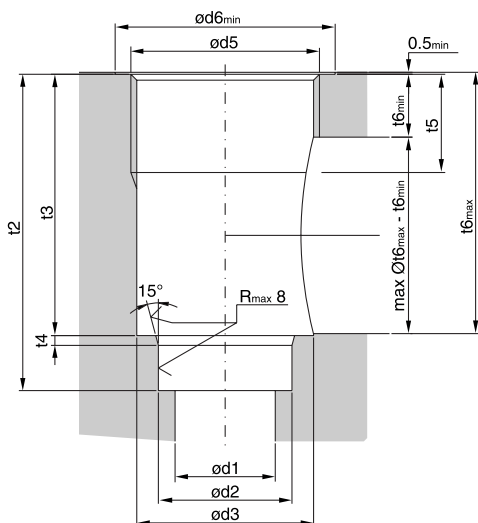

Size	NG16	NG25	NG32
d1	18	25.5	36
d2 <sup>H7</sup>	25	34	45
d3	31	45	57
d5	M33x2	G1½"	G2"
d6 <sub>min</sub>	41	56	73
t2 <sup>+0.1</sup>	66	80.5	99.5
t3	53	66.5	84.5
t4	2	2.5	2.5
t5	21	25	30
t6 <sub>min</sub>	16	16	24
t6 <sub>max</sub>	52.5	66	84
t7	6.5	6.5	10

SPZBE\_UK.INDD RH



The check valve series SPV and SPZ are designed as a threaded cartridge valve. All parts are assembled in one unit and easy to mount.

**Features**

- Little space required
- Leak-free
- Easy assembly

**Ports**

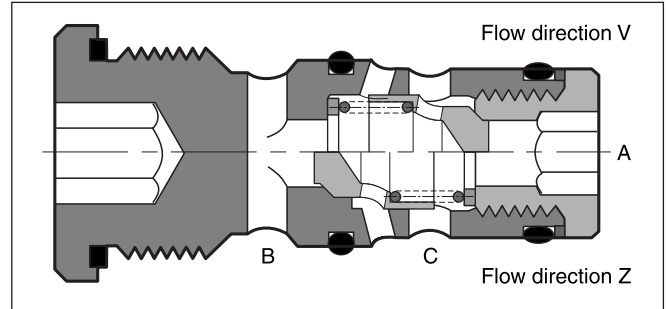
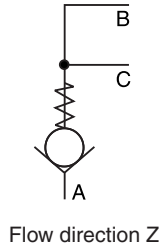
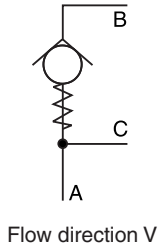

**Technical data**

<b>Design</b>		Threaded cartridge valve	
Mounting position		Unrestricted	
Ambient temperature		[°C] -40 ... +60	
Nominal size		NG06	NG10
Weight		0.5	0.8
<b>Hydraulic</b>		See symbols	
Flow direction		Hydraulic oil as per DIN 51 524 ... 536	
Fluid			
Viscosity		recommended [cSt] [mm²/s]	30 ... 80
		permitted [cSt] [mm²/s]	20 ... 380
Fluid temperature		[°C] -20 ... +60	
Filtration		ISO 4406 (1999); 18/16/13	
Nominal pressure		[bar] 350	
Opening pressure		[bar] 0.3	
Flow		40	60

**Ordering code**

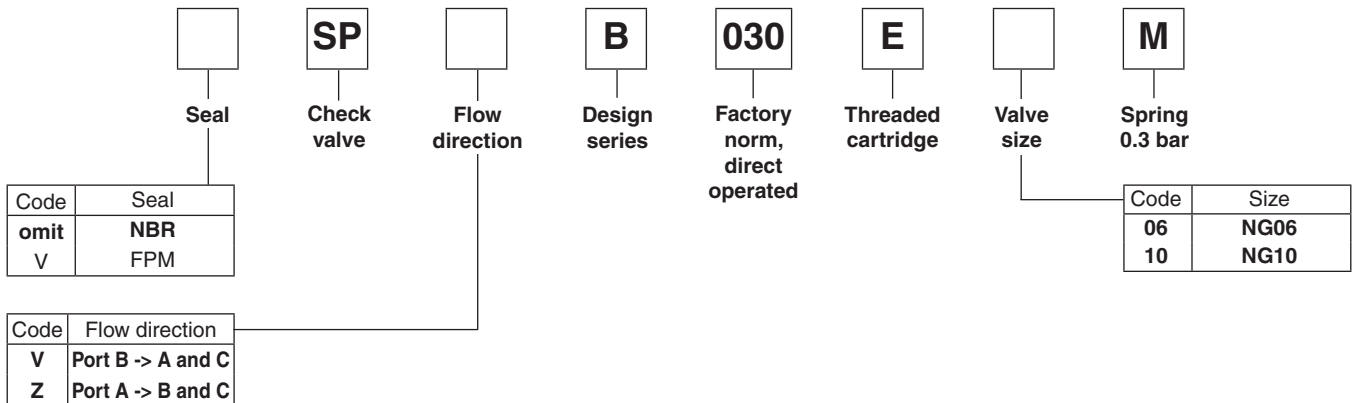

**Bold letters =  
Short-term availability**

**Dimensions**

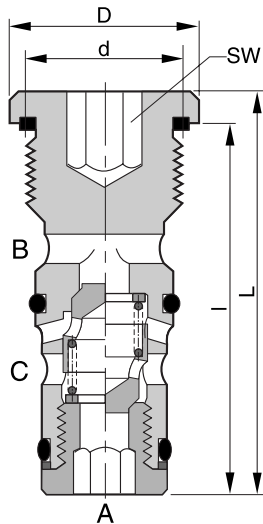

Dimensions	NG06	NG10
D	24	34
L	50	74
d	M18x1.5	M24x1.5
l	45	66
SW	8	12

**6**

**Seal kits**

NG	NBR seals	FPM seals
06	SK-SPV/ZB0E06	SK-SPV/ZB0E06V
10	SK-SPV/ZB0E10	SK-SPV/ZB0E10V

**Mounting cavity**

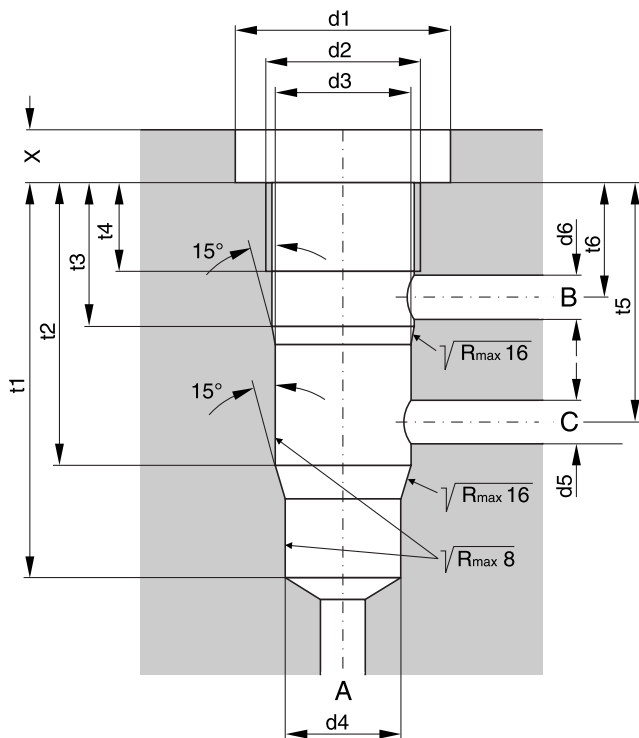

Dimensions	NG06	NG10
d1	25	35
d2	M18 x 1.5	M24 x 1.5
d3 <sup>H7</sup>	16	22
d4 <sup>H7</sup>	14	20
d5 <sub>max.</sub>	6	9
d6 <sub>max.</sub>	6	9
t1	45	68
t2	32	51
t3	16	20
t4	10	15
t5	27.5	40
t6	12	13.5

### Characteristics

### Check Valves Series SPR (Parker), C4V (Denison)

Direct operated check valves are available with both Parker (series SPR) and Denison (series C4V) ordering codes.

Check valves allow free flow from A to B. The counter direction is blocked. The SPR/C4V series are equipped with a leak-free seat type cartridge.

#### Function

The pressure arising in port A lifts the poppet from the valve seat and releases the flow to B. In the counter direction, the spring and the pressure on top of the cartridge hold the poppet onto the seat and block the flow.



C4V06

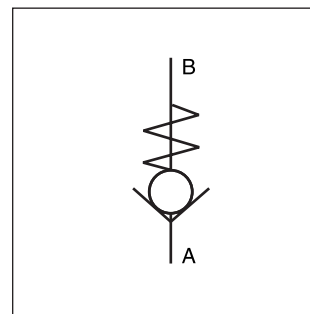

#### $\Delta p/Q$ performance curve

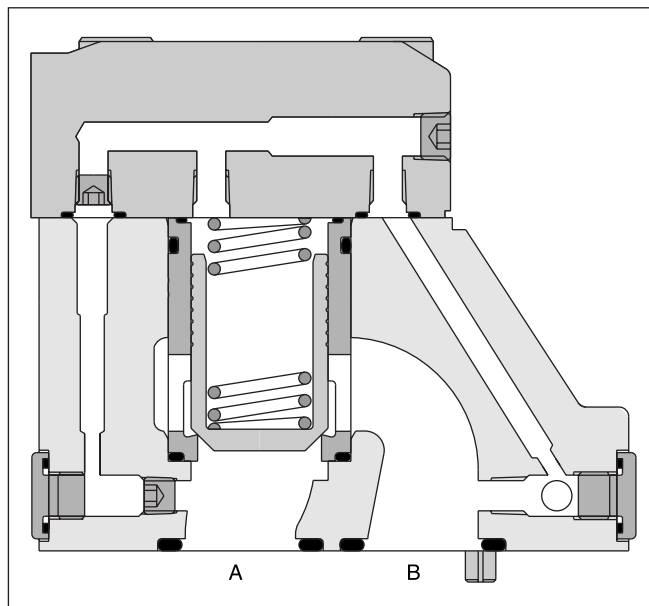
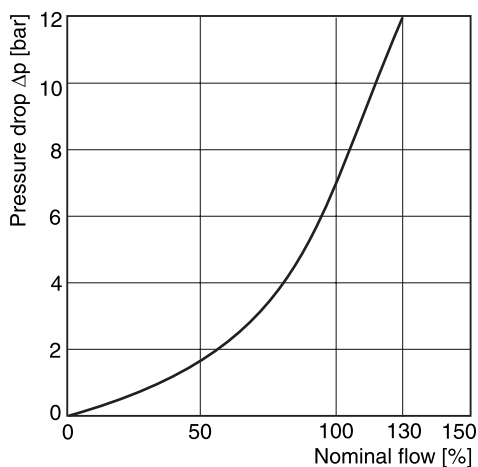

C4V10

6

#### Technical data

General				NG10	NG25	NG32
				Nominal size		
Subplate mounting		ISO 5781				
Mounting position		Unrestricted				
Ambient temperature	[°C]	-20...+80				
Weight	[kg]	2.8	4.6	6.1		
Hydraulic						
Max. operating pressure	[bar]	350				
Nominal flow	[l/min]	150	270	450		
Fluid		Hydraulic oil to DIN 51524				
Viscosity	recommended	[cSt]/[mm²/s]	30...50			
	permitted	[cSt]/[mm²/s]	20...380			
Fluid temperature	recommended	[mm²/s]	30...50			
	permitted	[mm²/s]	-20...+70			
Filtration		ISO 4406 (1999); 18/16/13				

## Check Valves Series SPR (Parker), C4V (Denison)

### Parker

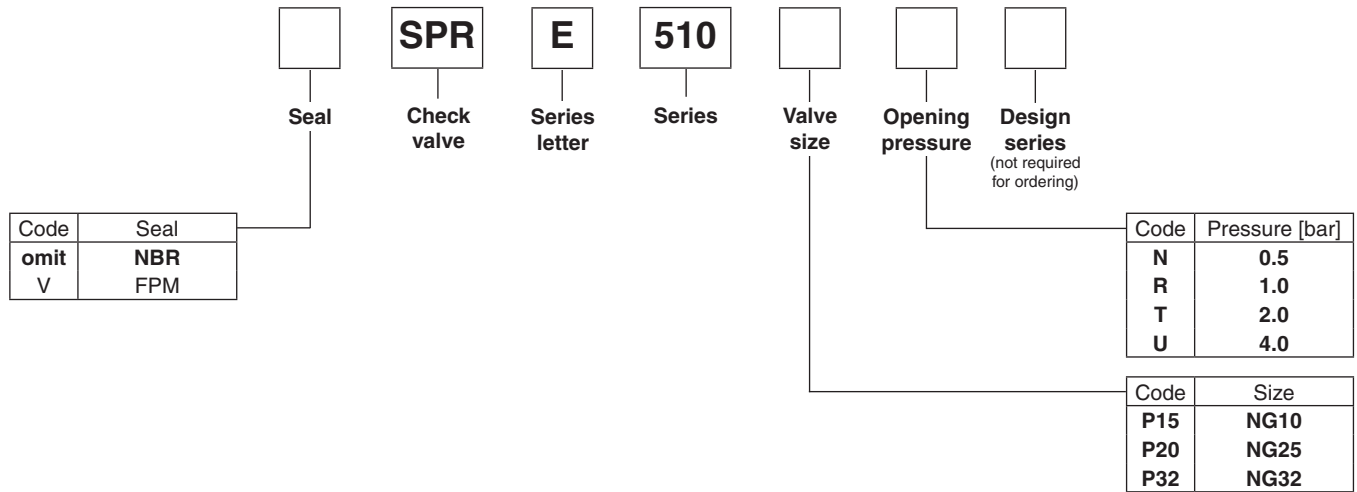

The Parker model code should be used for all new applications. Otherwise also refer to Denison model code.

### Denison

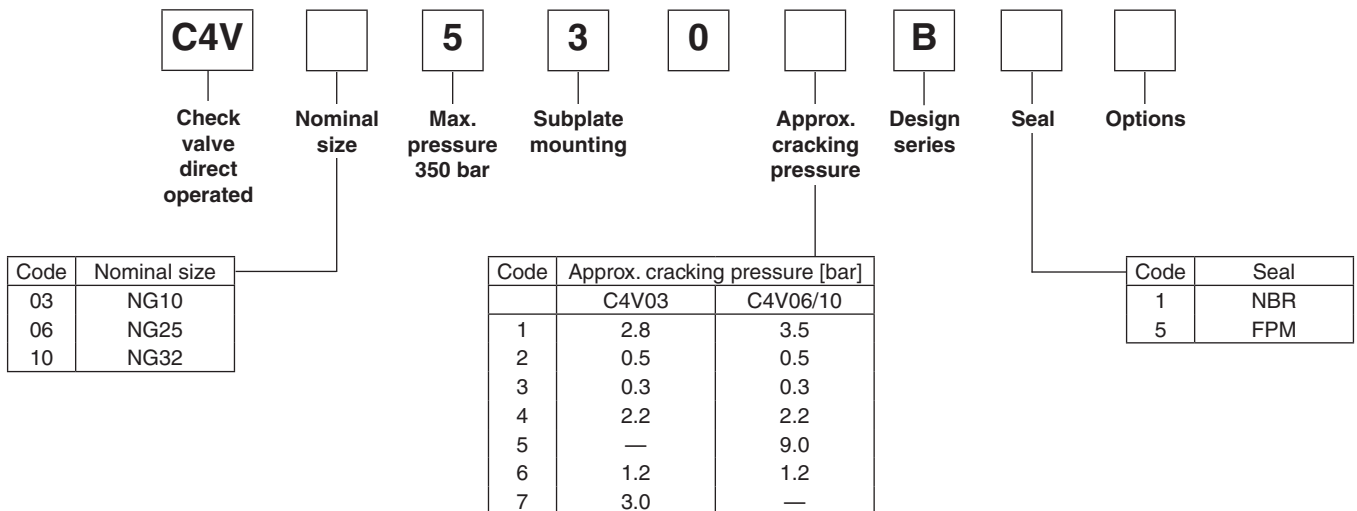

The Denison model code is available for existing applications. Otherwise also refer to Parker model code.

6

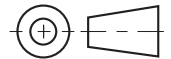
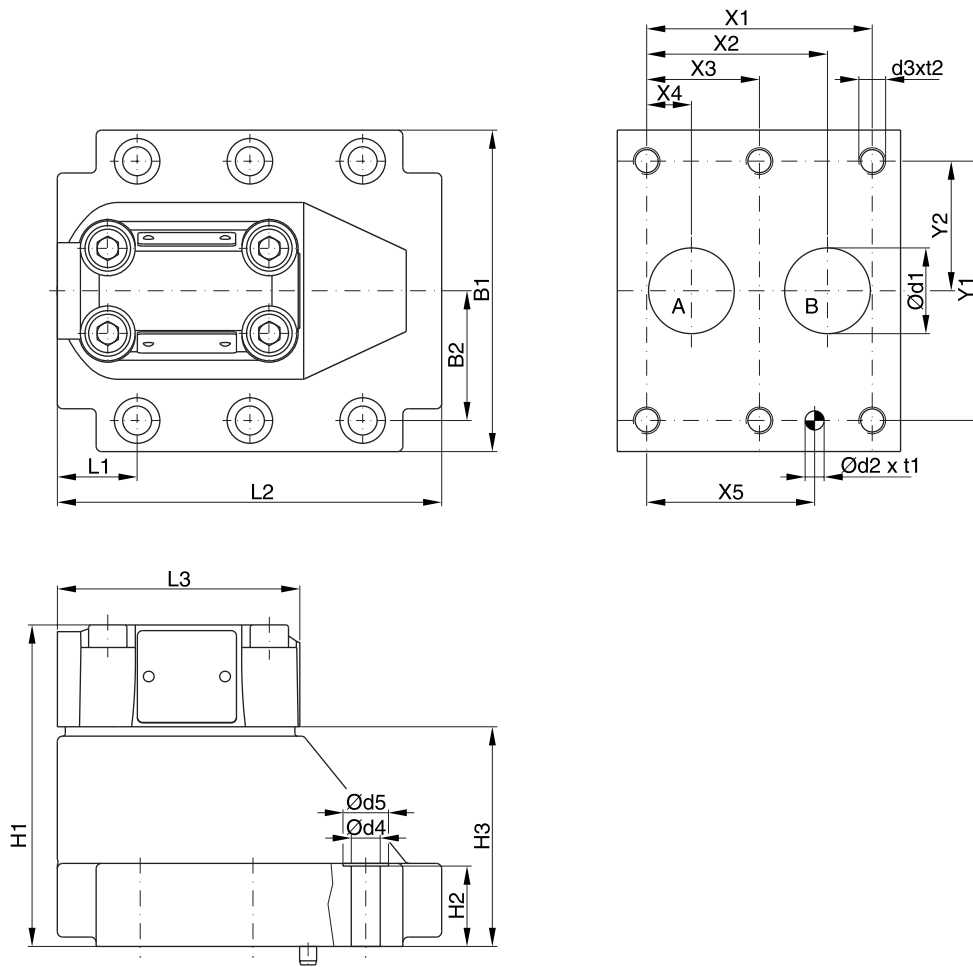

NG	ISO-code	x1	x2	x3	x4	x5	y1	y2	B1	B2	H1	H2	H3	L1	L2
10	5781-06-07-0-00	42.9	35.8	-	7.2	31.8	66.7	33.4	87.3	33.4	83	21	45	29	94.8
25	5781-08-10-0-00	60.3	49.2	-	11.1	44.5	79.4	39.7	105	39.7	109.5	29	71.5	34.7	126.8
32	5781-10-13-0-00	84.2	67.5	42.1	16.7	62.7	96.8	48.4	120	48.4	120	29	82	30.6	144.3

Tolerance for all dimensions ±0.2

NG	ISO-code	d1max	d2	t1	d3	t2	d4	d5
10	5781-06-07-0-00	15	7.1	8	M10	16	10.8	17
25	5781-08-10-0-00	23.4	7.1	8	M10	18	10.8	17
32	5781-10-13-0-00	32	7.1	8	M10	20	10.8	17

NG	ISO-code	Kit 		Kit		Surface finish
				NBR	FPM	
10	5781-06-07-0-00	BK-M10 x 35-4pcs	68 Nm	SK-SVLE5P10	SK-SVLE5P10V	$R_{max} 6.3$ $0.01/100$
25	5781-08-10-0-00	BK-M10 x 45-4pcs	68 Nm	SK-SVLE5P25	SK-SVLE5P25V	
32	5781-10-13-0-00	BK-M10 x 45-6pcs	68 Nm	SK-SVLE5P32	SK-SVLE5P32V	

SPR-C4V\_UK.INDD RH



Pilot operated check valves of the series CP allow free flow in one direction (A to B).

The counter-flow direction (B to A) is blocked. By applying pilot pressure, the poppet can be lifted from its seat against the pressure in port B. Thus flow in the counter-direction is also possible. There are 1 and 2 stage poppets available with pilot ratios of 1 : 5 and 1 : 40, to suit different operating conditions.

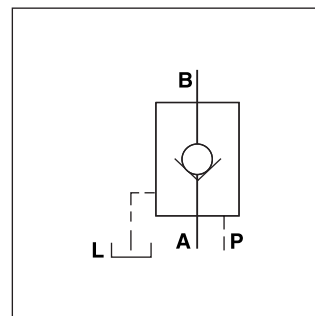
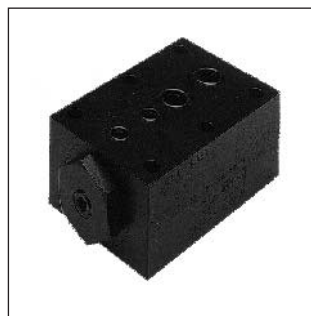

**Technical data**

Size		600	1200
Max. operating pressure	[bar]	210	210
Max. pilot pressure	[bar]	210	70
Flow Q <sub>max</sub> at Δp 2,7bar	[l/min]	30	95
Nominal size		3/8	3/4
Weight	[kg]	4	7

**Pilot ratios**

**Poppet 1 stage**

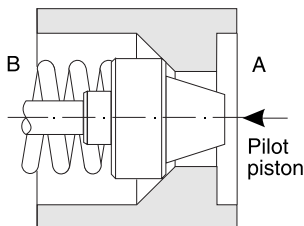

Surface ratio 5 : 1 (pilot spool: poppet surface) for quick response time without decompression.

**Poppet 2 stage**

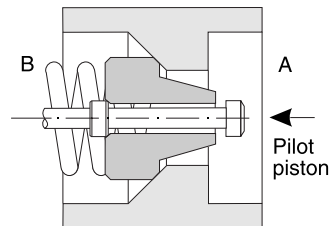

Surface ratio 40 : 1 (pilot spool: decompression pin surface) for low shock or oscillation performance from decompression.

**Ordering code**

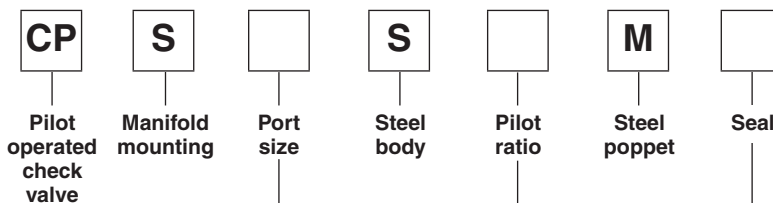

Code	Port size
600	NG06
1200	NG10

Code	Seal
omit	NBR
V	FPM

Code	Ratio	Stage
5	5:1	1
40	40:1	2

**Bold letters =  
Short-term availability**

$\Delta p/Q$  performance curves

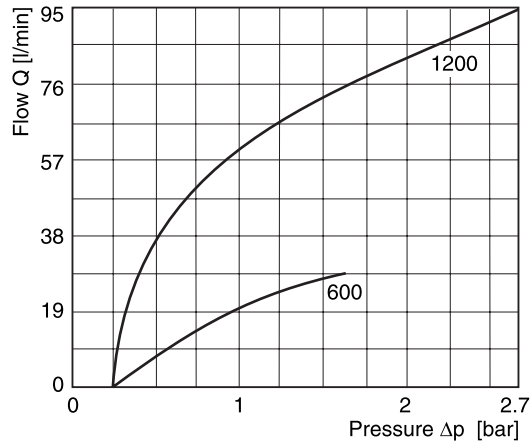

The curves refer to hydraulic oil of 33 cSt and 50°C.

Dimensions

6

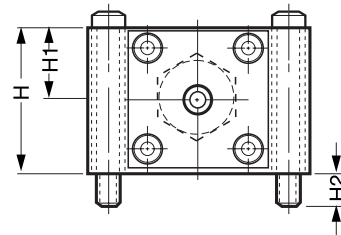
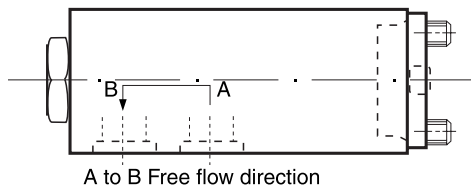

6 mounting screws  
M6 for size 600  
6 mounting screws  
M8 for size 1200

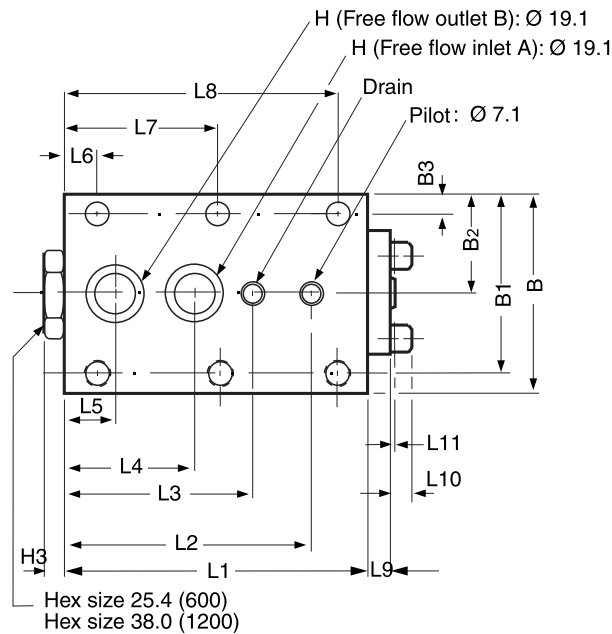

Size	L3	L2	L1	L9	L11	H	H1	H2	H3	L10	L8	L7	L6	B3	B2	B1	B	$\varnothing H$	L5	L4
CPS600S	76.2	101.6	120.7	10.7	1.0	50.8	25.4	12.7	7.9	-	108.0	60.2	12.7	8.6	38.1	67.3	76.2	11.2	21.3	53.3
CPS1200S	93.7	127.0	152.4	11.4	1.0	63.5	31.8	12.7	10.2	7.9	136.4	76.2	15.7	10.2	50.8	91.2	101.6	19.1	25.4	63.5

**Characteristics**

**Directional Seat Valve  
Series D4S (Denison)**

Seat valves series D4S are designed for directional control functions. A large variety of poppets, springs and covers - including shuttle valves, stroke limiters, solenoid valves (VV01) and position control - allow to design individual hydraulic solutions for nominal flow up to 600 l/min.

A complete program is offered under the Denison brand: subplate mounted valves (D4S - chapter 6), SAE flange valves (D5S - chapter 9), pipe mounted valves (D4S - chapter 10), slip-in cartridges (CAR - on request).

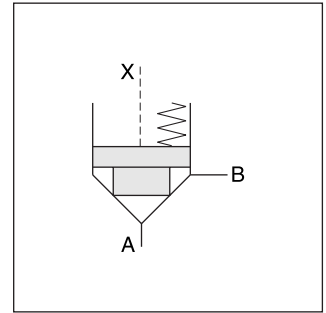
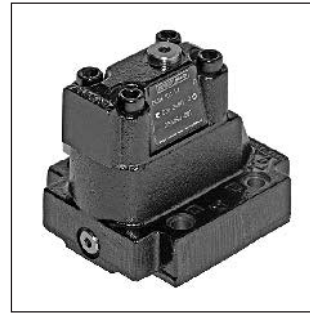

**Features**

- Leak-free seat valve design
- Numerous pilot options
- 6 poppet types
- 3 sizes, NG10, 25, 32

**D4S10**

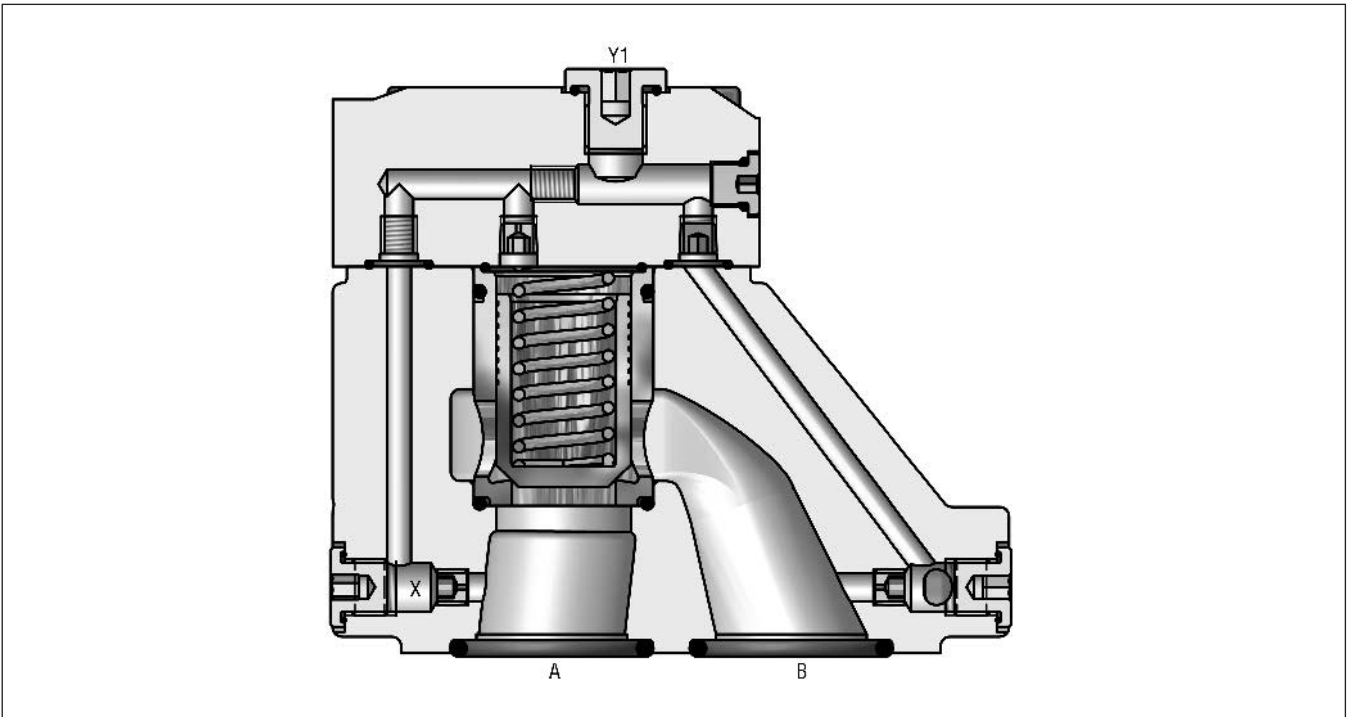

# Directional Seat Valve Series D4S (Denison)

## Ordering Code



**Seat valve**  
Nominal size  
Subplate mounting ISO 6264 Y1 port G¼"  
Pilot connection  
Cap version  
Sleeve  
Spool type  
Spring  
Switching type  
Solenoid voltage  
Design series  
Seals  
Options

Code	Nominal size
03	NG10
06	NG25
10	NG32

Code	Pilot oil line in body	Pilot connection	
		A-X	B-Y
1	internal from A	●	○
2	internal from X	●	○
A <sup>1)</sup>	internal from A	●	●
B <sup>1)</sup>	external from X	○	●
C	internal from A + B	●	●
D	internal from B	●	○
G	external from Y	●	●

<sup>1)</sup> With VV01 only

Code	Ports	X	Y	Z	X-Y	Y1	VV01
Standard							
1	Pilot oil = pilot drain	—	●	●	○	●	—
C	Pilot oil = pilot drain	●	○	●	○	●	—
With solenoid valve (VV01)							
2	Ext. PD from cap	—	○	●	●	○	●
6	Internal pilot drain	—	○	●	●	●	—
With stroke limiter (not for D4S03)							
3	Pilot oil = pilot drain	●	●	—	—	—	—
4	Pilot oil = pilot drain	●	●	—	—	—	—

○ open bore ● closed bore ◐ orifice Ø 1.2

Code	Sleeve
1	AA=95%, AB=5%
3	AA=60%, AB=40%

Code	Size	Poppet type	Sleeve
1	03, 06, 10	With closed bottom and 15° chamfer (pZ max. = pA +20bar)	1
2	03	With 0.8 dia. orifice at the bottom and 15° chamfer	1
	06, 10	With 1.2 dia. orifice at the bottom and 15° chamfer	1
4	03, 06, 10	With closed bottom and 45° chamfer	1, 3
A <sup>2)</sup>	06, 10	Safety spool (for position control only)	3
B <sup>2)</sup>	06, 10	Throttle spool, 10° chamfer	3
C <sup>2)</sup>	06, 10	Throttle spool, 3° chamfer	3

<sup>2)</sup> Springs 2, 3, 4 and 6 only

Code	Options
omit	Standard
013	Cover for end position control

Code	Seals
1	NBR
5	FPM

Code	Solenoid voltage
omit	Standard
G0R	12V=
G0Q	24V=
GAR	98V=
GAG	205V=
W06	115V / 50Hz
W07	230V / 50Hz

Code	Switching type
omit	Standard
09	VV01 with manual override
10	VV01 without manual override
11	VV01 with manual override
12	VV01 without manual override
CA	Shuttle valve
DA	Shuttle valve
CB	VV01 code 09 and shuttle valve code CA
CD	VV01 code 11 and shuttle valve code CA
DB	VV01 code 09 and shuttle valve code DA
DD	VV01 code 11 and shuttle valve code DA
BH	VV01 code 10 and shuttle valve code CA and position control <sup>3)</sup> with amplifier
BK	VV01 code 12 and shuttle valve code CA and position control <sup>3)</sup> with amplifier
BN	VV01 code 10 and shuttle valve code DA and position control <sup>3)</sup> with amplifier
BQ	VV01 code 12 and shuttle valve code DA and position control <sup>3)</sup> with amplifier
BC	VV01 code 10 and position control <sup>3)</sup> with amplifier
BE	VV01 code 12 and position control <sup>3)</sup> with amplifier
BA	Position control <sup>3)</sup> with amplifier
BF	Position control <sup>3)</sup> with amplifier and shuttle valve code CA
BL	Position control <sup>3)</sup> with amplifier and shuttle valve code DA

<sup>3)</sup> Position control for D4S06/10 only.  
Spring 2 or 4. Spool A and sleeve 3.  
Valve open: proximity switch damped.

Code	Spring (approx. cracking pressure [bar])					
	Sleeve Code 1		Sleeve Code 3			
	A -> B		A -> B		B -> A	
	D5S03	D5S06/10	D5S03	D5S06/10	D5S03	D5S06/10
1	2.8	3.5	6.5	6.5	9.5	11.0
2	0.5	0.5	1.0	1.0	1.5	1.7
3	0.3	0.3	0.6	0.6	0.9	1.0
4	2.2	2.2	4.0	3.5	5.5	6.0
5	—	9.0	—	16.0	—	28.0
6	1.2	1.2	2.0	2.2	3.0	3.8
7	3.0	—	8.0	—	12.0	—

<b>General</b>		03		06		10	
		Size					
Mounting	Subplate mounting acc. to ISO 6264						
Mounting position	unrestricted						
Ambient temperature	[°C]	-20...+50					
Weight	[kg]	2.7		4.5		6.0	
<b>Hydraulic</b>							
Operating pressure	[bar]	Ports A, B up to 350; Port Y 140 (with VV01)					
Nominal flow	[l/min]	180		360		600	
Fluid	Hydraulic oil as per DIN 51524...525						
Fluid temperature	[°C]	-20...+80					
Viscosity permitted	[cSt]/[mm <sup>2</sup> /s]	10...650					
Viscosity recommended	[cSt]/[mm <sup>2</sup> /s]	30					
Filtration	ISO 4406 (1999) 18/16/13 (acc. NAS 1638: 7)						
<b>Electrical (solenoid)</b>							
Duty ratio	[%]	100					
Response time	[ms]	Energized / de-energized AC: 20/18 , DC: 46/27					
Code		G0R	G0Q	GAR	GAG	W06	W07
Supply voltage	[V]	12V =	24V =	98V =	205V =	150 at 50Hz	230 at 50Hz
Tolerance supply voltage	[%]	+5...-10	+5...-10	+5...-10	+5...-10	+5...-10	+5...-10
Power consumption, hold	[W]	31	31	31	31	78	78
Power consumption, in rush	[W]	31	31	31	31	264	264
Max. switching frequency	[1/h]	AC: up to 7.200, DC: up to 16.000					
Solenoid connection	Connector as per EN175301-803						
Protection class	IP65 in accordance with EN 60529 (plugged and mounted)						
Coil insulation class	H (180 °C)						

**6**

**D4S pilot configuration**

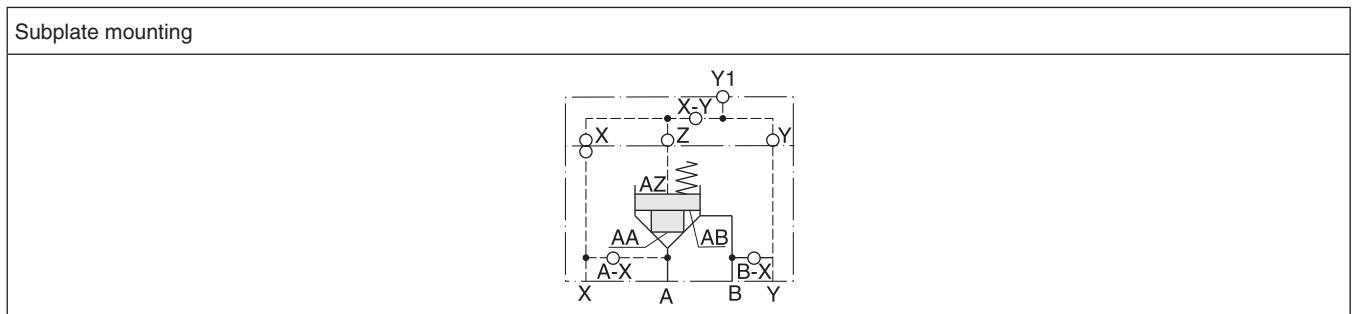

Characteristics

$\Delta p/Q$  performance curves

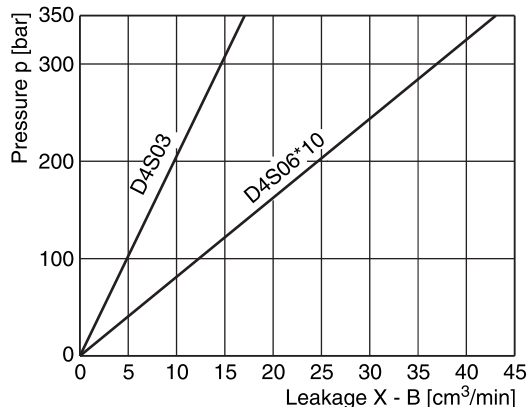
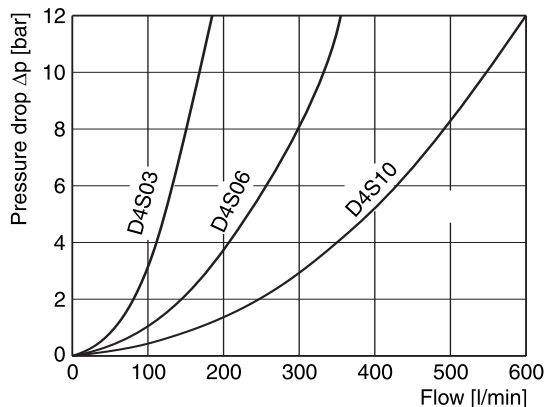

6

Selection of Cartridges

Sleeve 1, poppet 1	Sleeve 1, poppet 2	Sleeve 1, poppet 4	Sleeve 3, poppet 4	Sleeve 3, poppet A	Sleeve 3, poppet B/C
C	C	C	C	C	C
A	A	A	A	A	A
1 : 1.05 $A_A = 0.95 A_C$ $A_B = 0.05 A_C$ 15° chamfer	1 : 1.05 $A_A = 0.95 A_C$ $A_B = 0.05 A_C$ 15° chamfer orifice	1 : 1.05 $A_A = 0.95 A_C$ $A_B = 0.05 A_C$ 45° chamfer	1 : 1.67 $A_A = 0.6 A_C$ $A_B = 0.4 A_C$ 45° chamfer	1 : 1.67 $A_A = 0.6 A_C$ $A_B = 0.4 A_C$ 45° chamfer safety spool	1 : 1.67 $A_A = 0.6 A_C$ $A_B = 0.4 A_C$ 45° chamfer throttle spool

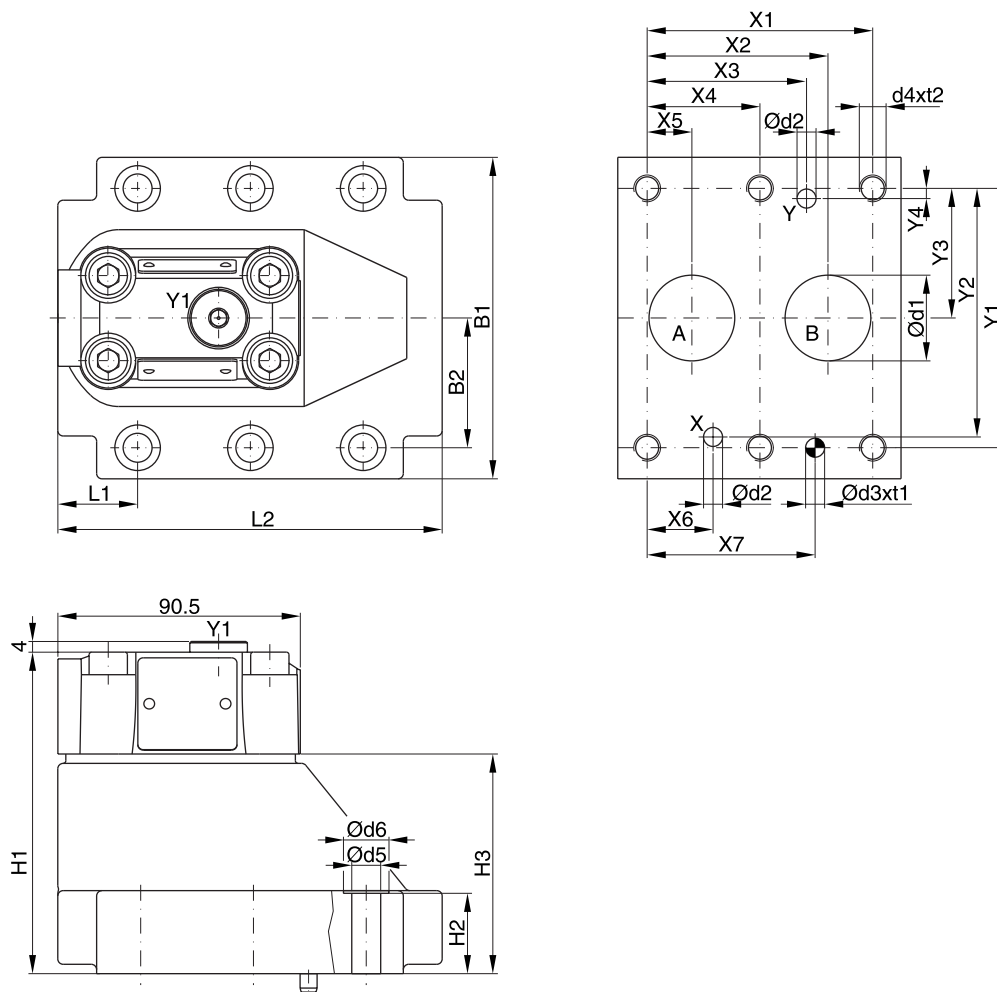



**6**

NG	ISO-code	X1	X2	X3	X4	X5	X6	X7	Y1	Y2	Y3	Y4
10	6264-06-09-*-97	42.9	35.8	21.5	-	7.2	21.5	31.8	66.7	58.8	33.4	7.9
25	6264-08-13-*-97	60.3	49.2	39.7	-	11.1	20.6	44.5	79.4	73	39.7	6.4
32	6264-10-17-*-97	84.2	67.5	59.5	42.1	16.7	24.6	62.7	96.8	92.8	48.4	3.8

NG	ISO-code	B1	B2	H1	H2	H3	L1	L2	D1	D2	D3	t1	D4	t2	D5	D6
10	6264-06-09-*-97	87.3	33.35	83	21	45	29	94.8	15	7	7.1	8	M10	16	10.8	17
25	6264-08-13-*-97	105	39.7	109.5	29	71.5	34.7	126.8	23.4	7.1	7.1	8	M10	18	10.8	17
32	6264-10-17-*-97	120	48.4	120	29	82	30.6	144.3	32	7.1	7.1	8	M10	20	10.8	17

NG	ISO-code	Bolt kit -  DIN912 12.9		Kit 		Surface finish 
				NBR	FPM	
10	6264-06-07-*-97	BK-M10 x 35-4pcs	63 Nm ±15%	SK-R10MN50	SK-R10MV50	
25	6264-08-11-*-97	BK-M10 x 45-4pcs	63 Nm ±15%	SK-R25MN50	SK-R25MV50	
32	6264-10-15-*-97	BK-M10 x 45-6pcs	63 Nm ±15%	SK-R32MN50	SK-R32MV50	

D4S\_UK.INDD RH

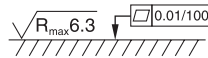
D4S direct operated

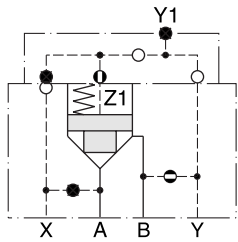

D4S...-DC  
Pilot oil Y = internal from B

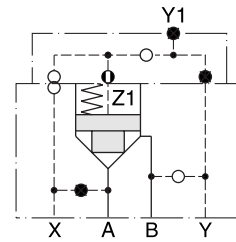

D4S...-21  
Pilot oil X = external

D4S with VV01

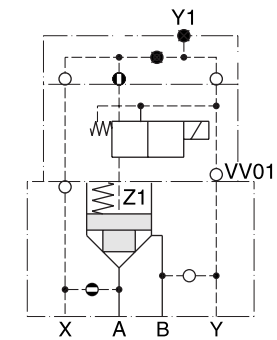

D4S...-16-... } with VV01  
09  
10  
11  
12  
Pilot oil X = internal from A  
Drain Y = internal to B

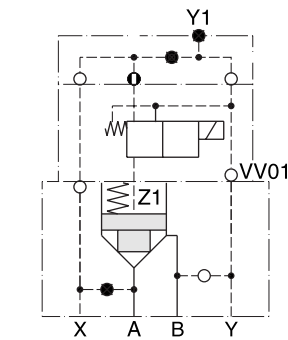

D4S...-26-... } with VV01  
09  
10  
11  
12  
Pilot oil X = external  
Drain Y = internal to B

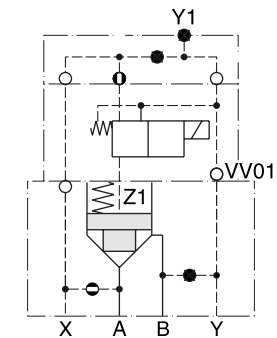

D4S...-A5-... } with VV01  
09  
10  
11  
12  
Pilot oil X = internal from A  
Drain Y = external to subplate

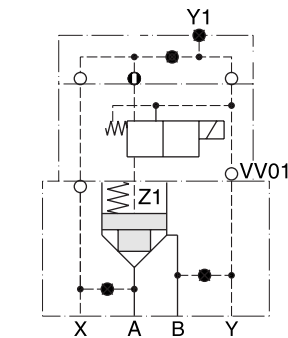

D4S...-B5-... } with VV01  
09  
10  
11  
12  
Pilot oil X = external  
Drain Y = external to subplate

6

D4S with VV01

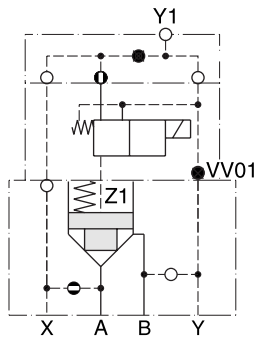

D4S...-12-...-  
09 } with VV01  
10 }  
11 }  
12 }

Pilot oil X = internal from A  
Drain Y1 = external out of the cap

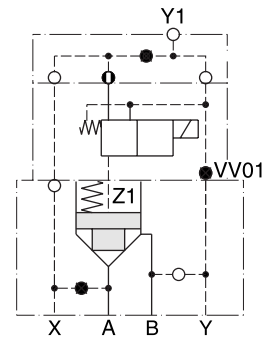

D4S...-22-...-  
09 } with VV01  
10 }  
11 }  
12 }

Pilot oil X = external  
Drain Y1 = external out of the cap

D4S with shuttle valve

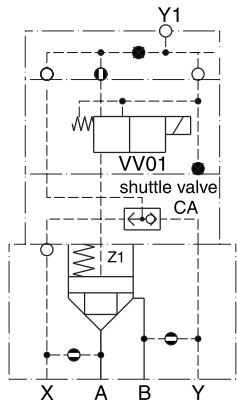

D4S...-C2-...-  
CB } with shuttle valve CA  
CD } and VV01

Pilot oil = internal from A and B  
Drain Y1 = external out of the cap

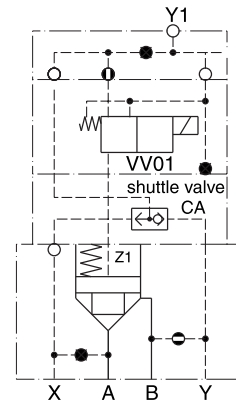

D4S...-D2-...-  
CB } with shuttle valve CA  
CD } and VV01

Pilot oil = internal from B and  
external from X  
Drain Y1 = external out of the cap

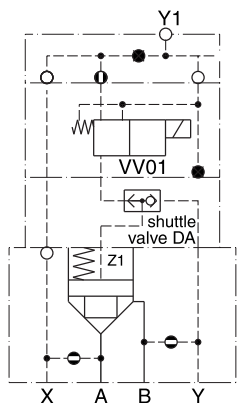

D4S...-C2-...-  
DB } with shuttle valve DA  
DD } and VV01

Pilot oil = internal from A and B  
(B-A = Check valve function)  
Drain Y1 = external out of the cap

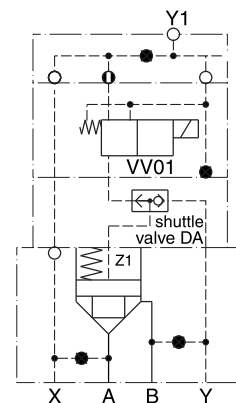

D4S...-B2-...-  
DB } with shuttle valve DA  
DD } and VV01

Pilot oil = external from X and Y  
Drain Y1 = external out of the cap

D4S with position control

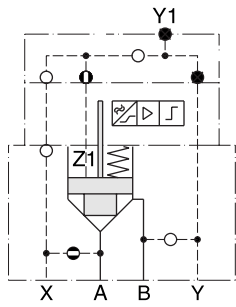

D4S...11-3A-BA  
(with position control)

Pilot oil X = internal from A

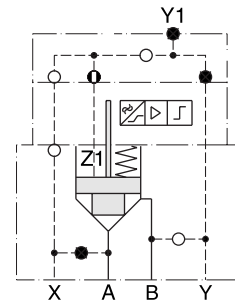

D4S...21-3A-BA  
(with position control)

Pilot oil X = external

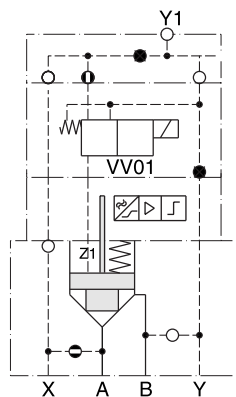

D4S...12-3A-BC } with position control  
BE } and VV01

Pilot oil X = internal from A  
Drain Y1 = external out of the cap

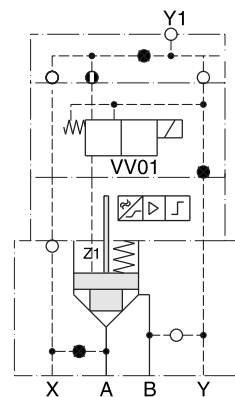

D4S...22-3A-BC } with position control  
BE } and VV01

Pilot oil X = external  
Drain Y1 = external out of the cap

D4S with stroke limiter

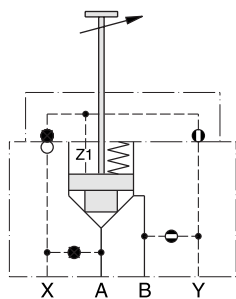

D4S...D4-34. with stroke limiter  
Pilot oil Y = internal from B

Note: for D4S06 and D4S10 only

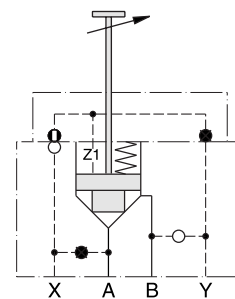

D4S...23-3B. with stroke limiter  
Pilot oil X = external

Note: for D4S06 and D4S10 only

6

**Dimensions D4S with VV01**

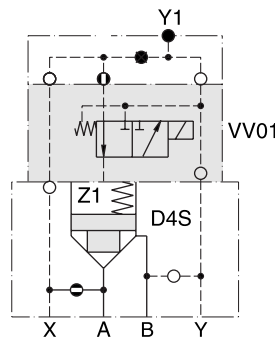
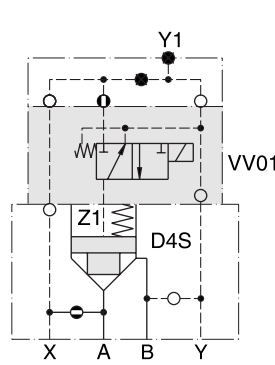
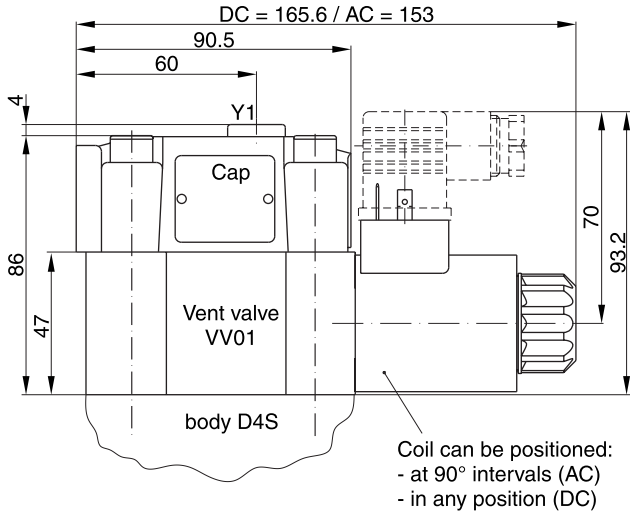

**Dimensions D4S with shuttle valve**

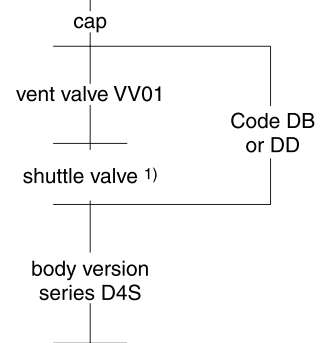
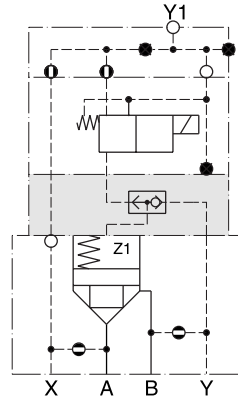
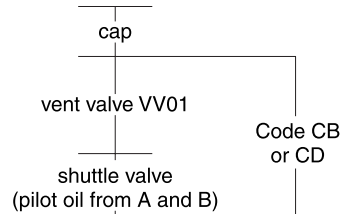
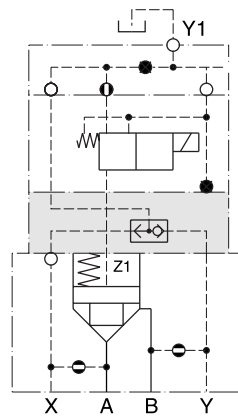
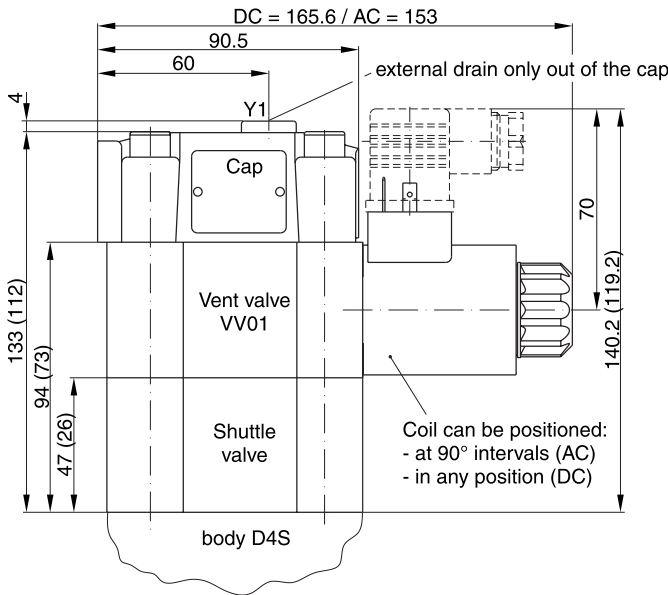

( ) Dimensions in brackets are for version VV01 with shuttle valve code DB or DD.

Note: Shuttle valves only use in connection with vent valve VV01.

1) pilot oil from A and B, from B to A check valve function

**Dimensions**

**Dimensions D4S position control**

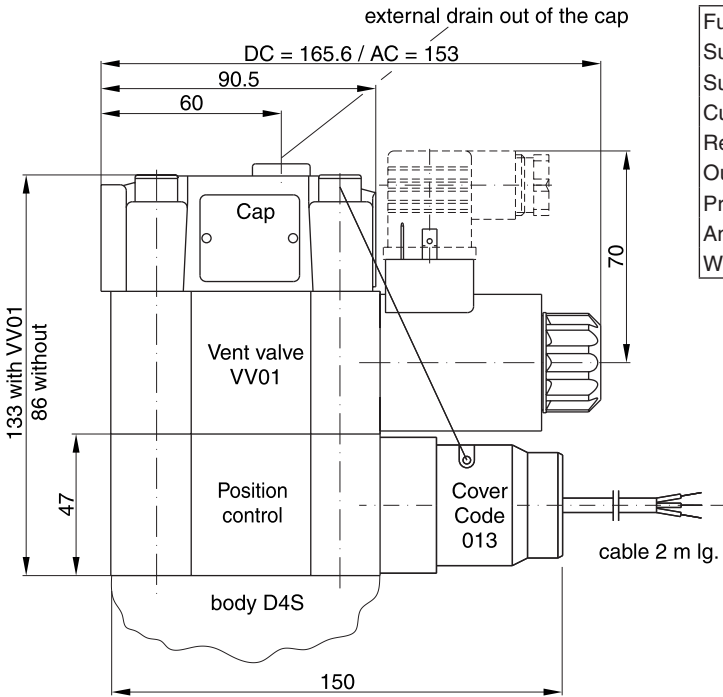

**Technical data (proximity switch)**

Function	PNP, contact
Supply voltage (U <sub>s</sub> )	[VDC] 10...30
Supply voltage ripple	[%] ≤ 10
Current consumption	[mA] max. 8
Residual voltage L-signal	[V] U <sub>s</sub> - 2.2 at I <sub>max</sub>
Output current (I)	[mA] ≤ 200
Protection class	IP67
Ambient temperature	[C°] -25...+70
Wire cross section	[mm <sup>2</sup> ] 3 x 0.5

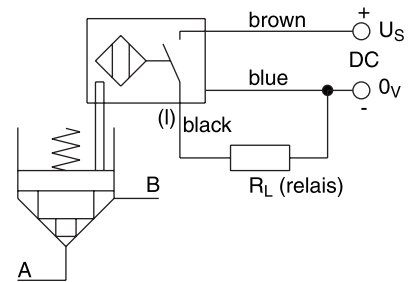
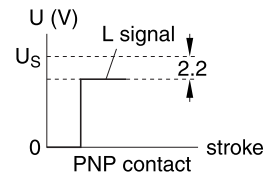

**Position control by proximity switch (incl. amplifier)**

Valve open: proximity switch activated.

This proximity switch is pressure proof and has no wearing parts.

**Note**

Position control for D4S06 and D4S10 only.

**Dimensions D4S stroke limiter**

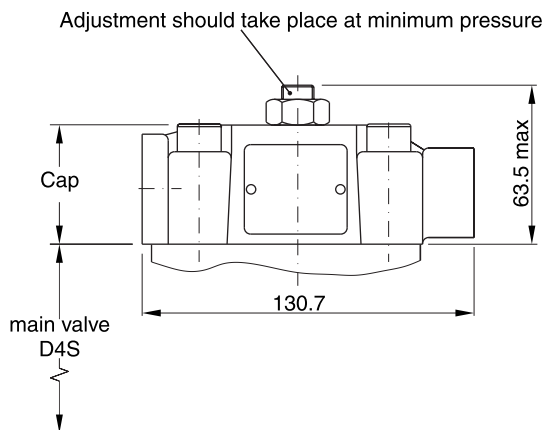

Example: D4S<sup>06</sup><sub>10</sub>-23-3B.

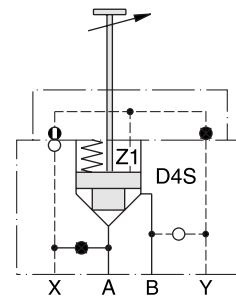

**Note:**

Stroke limiter not for use with D4S03, vent valve VV01, shuttle valve and position control.

### Characteristics

### Hydraulically Pilot Operated Check Valves Series SVLE (Parker), C4V (Denison)

Pilot operated check valves are available with both Parker (series SVL) and Denison (series C4V) ordering codes. Hydraulically pilot operated check valves allow free flow from A to B. The counter-flow direction is blocked.

When pressure is applied to control port X, the ring chamber flow from B to A is released.

Up to four different pilot control ratios are available (see ordering code).

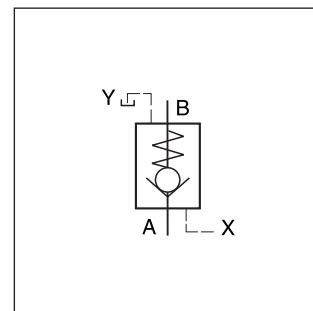

### Function

When no pressure is applied to the X-port, the flow from B to A is blocked, because the pressure in B is also in effect on top of the poppet.

Pressurizing the X port relieves the area on top of the poppet to the drain port and allows flow from B to A.

The seat design of the SVL valve series provides leak-free separation of port A and B in the closed position.

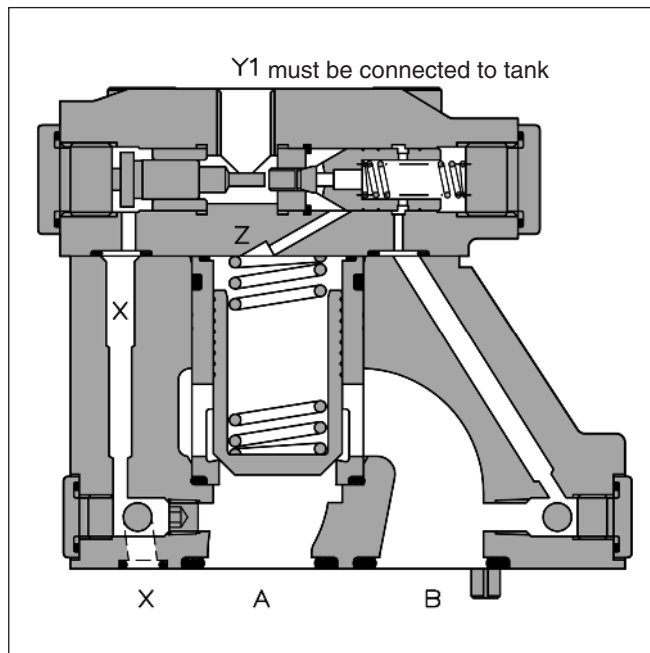

### Δp/Q flow curve

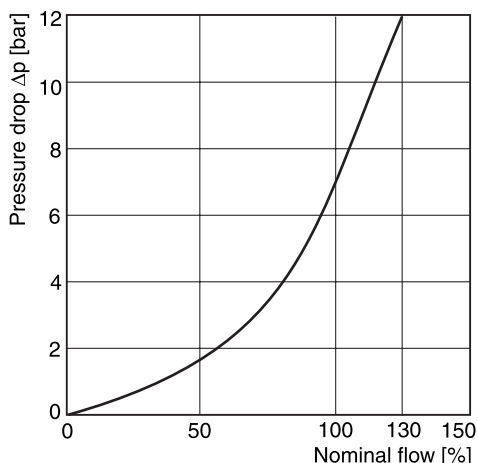

6

### Technical data

General				NG10			NG25			NG32					
				ISO 5781			Unrestricted			-20...+80					
Nominal size															
Subplate mounting															
Mounting position															
Ambient temperature	[°C]														
Weight	[kg]			2.8			4.6			6.1					
Hydraulic				350			150			270			450		
Max. operating pressure	[bar]														
Nominal flow	[l/min]														
Fluid				Hydraulic oil to DIN 51524											
Viscosity	recommended	[cSt]	[mm²/s]	30...50											
	permitted	[cSt]	[mm²/s]	20...380											
Fluid temperature	recommended	[mm²/s]		30...50											
	permitted	[mm²/s]		-20...+70											
Filtration				ISO 4406 (1999); 18/16/13											

SVLE-C4V\_UK.INDD RH



Ordering Code

Parker

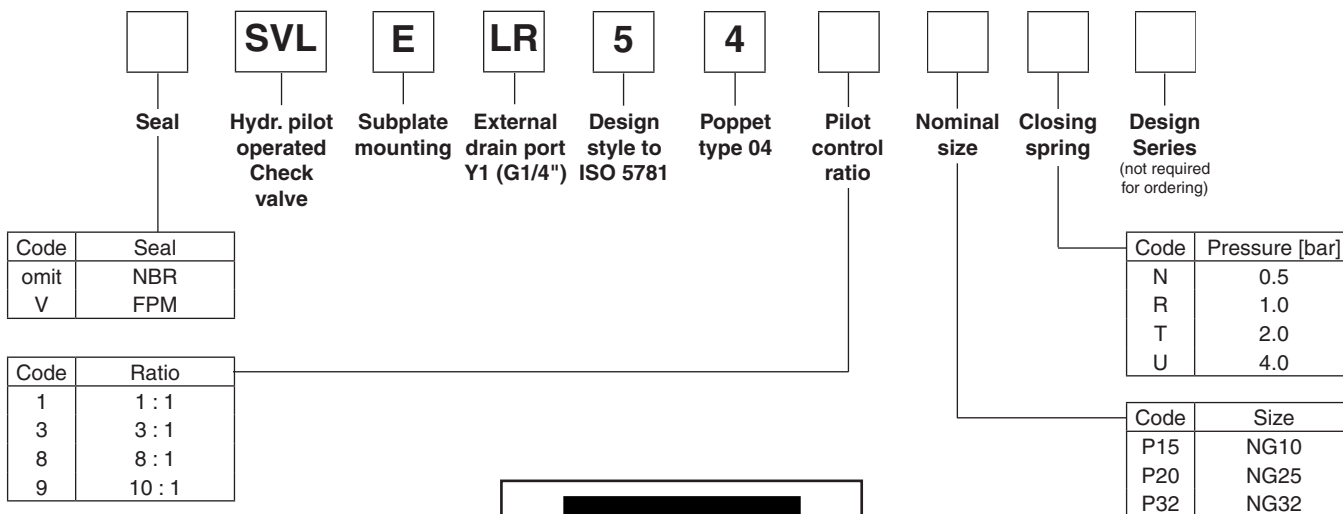

The Parker model code should be used for all new applications. Otherwise also refer to Denison model code.

6

Denison

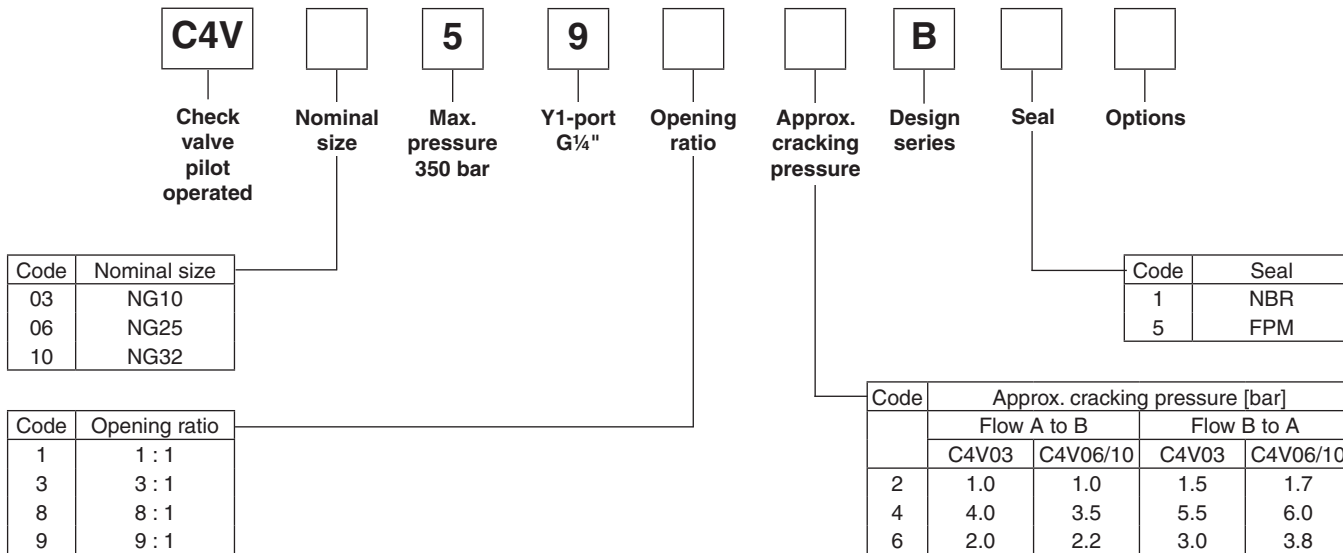

The Denison model code is available for existing applications. Otherwise also refer to Parker model code.



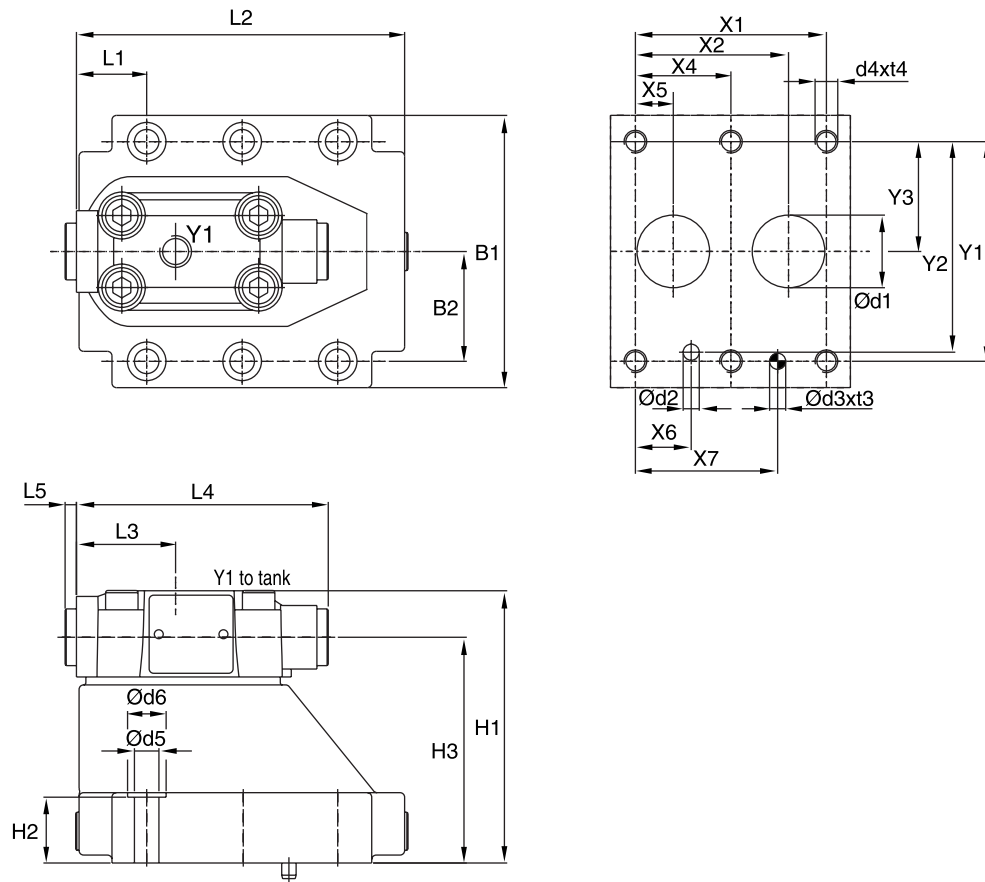

NG	ISO-code	x1	x2	x3	x4	x5	x6	x7	y1	y2	y3	y4	y5	y6
10	5781-06-07-0-00	42.9	35.8	-	-	7.2	21.5	31.8	66.7	58.8	33.4	-	-	-
25	5781-08-10-0-00	60.3	49.2	-	-	11.1	20.6	44.5	79.4	73	39.7	-	-	-
32	5781-10-13-0-00	84.2	67.5	-	42.1	16.7	24.6	62.7	96.8	92.8	48.4	-	-	-

Tolerance for all dimensions ±0.2

NG	ISO-code	B1	B2	H1	H2	H3	H4	H5	H6	L1	L2	L3	L4	L5	L6
10	5781-06-07-0-00	87.3	33.4	83	21	62.5	-	-	-	29.4	95.2	43.7	111	5	-
25	5781-08-10-0-00	105	39.7	109.5	29	89	-	-	-	35.1	127.2	43.7	111	5	-
32	5781-10-13-0-00	120	48.4	120	29	99.5	-	-	-	31	144.7	43.7	111	5	-

NG	ISO-code	d1max	d2max	d3	t3	d4	t4	d5	d6
10	5781-06-07-0-00	15	7	7.1	8	M10	16	10.8	17
25	5781-08-10-0-00	23.4	7.1	7.1	8	M10	18	10.8	17
32	5781-10-13-0-00	32	7.1	7.1	8	M10	20	10.8	17

NG	ISO-code	Kit		Surface finish
		Kit	Kit	
10	5781-06-07-0-00	BK-M10 x 35-4pcs	68 Nm	
25	5781-08-10-0-00	BK-M10 x 45-4pcs	68 Nm	
32	5781-10-13-0-00	BK-M10 x 45-6pcs	68 Nm	

SVLE-C4V\_UK.INDD RH



Description	Threaded cable joint	Body colour coding	Figures switching	Order no.
Plug DIN 43650, design type AF, protection class IP 65 Voltages up to 250 V	PG 9	black, B grey, A	Fig. 1	<b>5001710</b> <b>5001711</b>
	PG11	black, B grey, A	Fig. 1	<b>5001716</b> <b>5001717</b>

Fig. 1

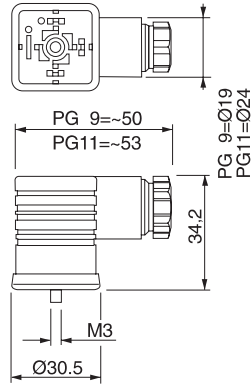

Other plugs on request

